

# Testing fresh concrete

## Part 5: Flow table test



ICS 91.100.30,

## National foreword

This British Standard is the UK implementation of EN 12350-5:2009. It supersedes BS EN 12350-5:2000 which is withdrawn.

The UK participation in its preparation was entrusted to Technical Committee B/517/1, Concrete production and testing.

A list of organizations represented on this committee can be obtained on request to its secretary.

This publication does not purport to include all the necessary provisions of a contract. Users are responsible for its correct application.

**Compliance with a British Standard cannot confer immunity from legal obligations.**



This British Standard was published under the authority of the Standards Policy and Strategy Committee on 31 May 2009

© BSI 2009

ISBN 978 0 580 58792 4

### Amendments/corrigenda issued since publication

Date	Comments

English Version

## Testing fresh concrete - Part 5: Flow table test

Essais pour béton frais - Partie 5: Essai d'étalement à la  
table à chocs

Prüfung von Frischbeton - Teil 5: Ausbreitmaß

This European Standard was approved by CEN on 20 January 2009.

CEN members are bound to comply with the CEN/GENELEC Internal Regulations which stipulate the conditions for giving this European Standard the status of a national standard without any alteration. Up-to-date lists and bibliographical references concerning such national standards may be obtained on application to the CEN Management Centre or to any CEN member.

This European Standard exists in three official versions (English, French, German). A version in any other language made by translation under the responsibility of a CEN member into its own language and notified to the CEN Management Centre has the same status as the official versions.

CEN members are the national standards bodies of Austria, Belgium, Bulgaria, Cyprus, Czech Republic, Denmark, Estonia, Finland, France, Germany, Greece, Hungary, Iceland, Ireland, Italy, Latvia, Lithuania, Luxembourg, Malta, Netherlands, Norway, Poland, Portugal, Romania, Slovakia, Slovenia, Spain, Sweden, Switzerland and United Kingdom.

EUROPEAN COMMITTEE FOR STANDARDIZATION  
COMITÉ EUROPÉEN DE NORMALISATION  
EUROPÄISCHES KOMITEE FÜR NORMUNG**Management Centre: Avenue Marnix 17, B-1000 Brussels**

## Contents

Page

Foreword.....	3
1 Scope .....	5
2 Normative references .....	5
3 Principle .....	5
4 Apparatus .....	5
5 Sampling .....	8
6 Procedure .....	9
7 Test results .....	10
8 Test report .....	10
9 Precision .....	10



## Foreword

This document (EN 12350-5:2009) has been prepared by Technical Committee CEN/TC 104 "Concrete and related products", the secretariat of which is held by DIN.

This European Standard shall be given the status of a national standard, either by publication of an identical text or by endorsement, at the latest by September 2009, and conflicting national standards shall be withdrawn at the latest by September 2009.

Attention is drawn to the possibility that some of the elements of this document may be the subject of patent rights. CEN [and/or CENELEC] shall not be held responsible for identifying any or all such patent rights.

This document supersedes EN 12350-5:1999.

This standard is one of a series concerned with testing concrete.

This series EN 12350 includes the following parts.

Part 1: Sampling;

Part 2: Slump-test;

Part 3: Vebe test;

Part 4: Degree of compactability;

Part 5: Flow table test;

Part 6: Density;

Part 7: Air content - Pressure methods;

Part 8: Self-compacting concrete - Slump-flow test (in preparation);

Part 9: Self-compacting concrete - V-funnel test (in preparation);

Part 10: Self-compacting concrete - L-box test (in preparation);

Part 11: Self-compacting concrete - Sieve segregation test (in preparation);

Part 12: Self-compacting concrete - J-ring test (in preparation).

**CAUTION — When cement is mixed with water, alkali is released. Take precautions to avoid dry cement entering the eyes, mouth and nose whilst mixing concrete. Prevent skin contact with wet cement or concrete by wearing suitable protective clothing. If cement or concrete enters the eye, immediately wash it out thoroughly with clean water and seek medical treatment without delay. Wash wet concrete off the skin immediately.**



The following amendments have been made to the 1999-10 edition of this standard:

- editorial revision
- indication that the test is not applicable for self-compacting concrete
- clarification of carrying out the test and the time for each cycle of lifting and dropping the mould to be between 1 s and 3 s (was not less than 2 s nor more than 5 s).

According to the CEN/CENELEC Internal Regulations, the national standards organizations of the following countries are bound to implement this European Standard: Austria, Belgium, Bulgaria, Cyprus, Czech Republic, Denmark, Estonia, Finland, France, Germany, Greece, Hungary, Iceland, Ireland, Italy, Latvia, Lithuania, Luxembourg, Malta, Netherlands, Norway, Poland, Portugal, Romania, Slovakia, Slovenia, Spain, Sweden, Switzerland and the United Kingdom.



## 1 Scope

This European standard specifies a method for determining the flow of fresh concrete. It is not applicable to self-compacting concrete, foamed concrete or no-fines concrete, nor to concrete with maximum aggregate size exceeding 63 mm.

NOTE The flow test is sensitive to changes in the consistency of concrete, which correspond to flow values between 340 mm and 600 mm. Beyond these extremes the flow table test may be unsuitable and other methods of determining the consistence should be considered.

## 2 Normative references

The following referenced documents are indispensable for the application of this document. For dated references, only the edition cited applies. For undated references, the latest edition of the referenced document (including any amendments) applies.

EN 12350-1, *Testing fresh concrete — Part 1: Sampling*

## 3 Principle

This test determines the consistency of fresh concrete by measuring the spread of concrete on a flat plate which is subjected to jolting.

## 4 Apparatus

**4.1 Flow table** (see Figure 1) consisting of: a moving table made from a flat plate with a plane area of  $(700 \pm 2) \text{ mm} \times (700 \pm 2) \text{ mm}$ , on which concrete can be placed, hinged to a rigid base onto which it can fall from a fixed height.

The flow table top shall have a flat metal surface with a minimum thickness of 2 mm. The metal surface shall not be readily attacked by cement paste or be liable to rusting. The flow table top shall have a mass of  $(16 \pm 0,5) \text{ kg}$  and may be detachable using a pin-hinge to allow weighing. The construction of the plate shall be such as to prevent distortion of the upper surface. The table top shall be hinged to the base in such a way that no aggregate can become trapped between the hinged surfaces.

The centre of the table shall be scribed with a cross, the lines of which run parallel to the edges of the plate and with a central circle  $(210 \pm 1) \text{ mm}$  in diameter.

At the front corners of the plate two hard and rigid blocks shall be firmly attached to the underside. They should not deform when wet and be non-absorbent. These stops shall transfer the load of the table top to the base without distorting the table. The base frame shall be constructed so that this load is transferred directly to the surface on which the apparatus is placed. This minimizes the tendency for the table top to bounce when allowed to fall freely.

Foot rests shall be provided to assist in stabilizing the table in use.

The fall height of the table top measured at the centre line of the front edge of the top plate shall be limited to  $(40 \pm 1) \text{ mm}$  by means of one or more stops.

For lifting the table top, a handle or lifting mechanism shall be provided to ensure that the top is lifted without jerking and allowed to fall freely over the entire lifting height.

**4.2 Mould**, to form the test specimen, made of metal not readily attacked by cement paste and not thinner than 1,5 mm. The interior of the mould shall be smooth and free from projections, such as protruding rivets and shall be free from dents. The mould shall be in the form of a hollow frustum of a cone having the following internal dimensions:

- diameter of base:  $(200 \pm 2)$  mm;
- diameter of top:  $(130 \pm 2)$  mm;
- height:  $(200 \pm 2)$  mm.

The base and the top shall be open and parallel to each other and at right angles to the axis of the cone. The mould shall be provided with two handles, on the upper portion, and fixing clamps or foot pieces on the bottom portion to hold it steady (see Figure 2). A mould which can be clamped to the base is acceptable provided the clamping arrangement can be fully released without movement of the mould or interference with the slumping concrete.

NOTE Magnets can be used to assist in positioning the mould.

**4.3 Tamping bar**, made of hard material, having a square section of side  $(40 \pm 1)$  mm and a length of approximately 200 mm. A further 120 mm to 150 mm may be turned to a circular section to form a handle to the bar (see Figure 3)

**4.4 Rule or measuring tape**, of minimum length 700 mm and having sub-divisions not greater than 5 mm along its entire length.

**4.5 Remixing container**, flat tray of rigid construction and made from a non-absorbent material not readily attacked by cement paste. It shall be of appropriate dimensions such that the concrete can be thoroughly re-mixed, using the square-mouthed shovel.

**4.6 Shovel**, with square mouth

NOTE The square mouth is required to ensure proper mixing of concrete on the remixing container.

**4.7 Moist cloth**

**4.8 Scoop**, approximately 100 mm in width.

**4.9 Timer or watch**, capable of measuring time to 1 s.



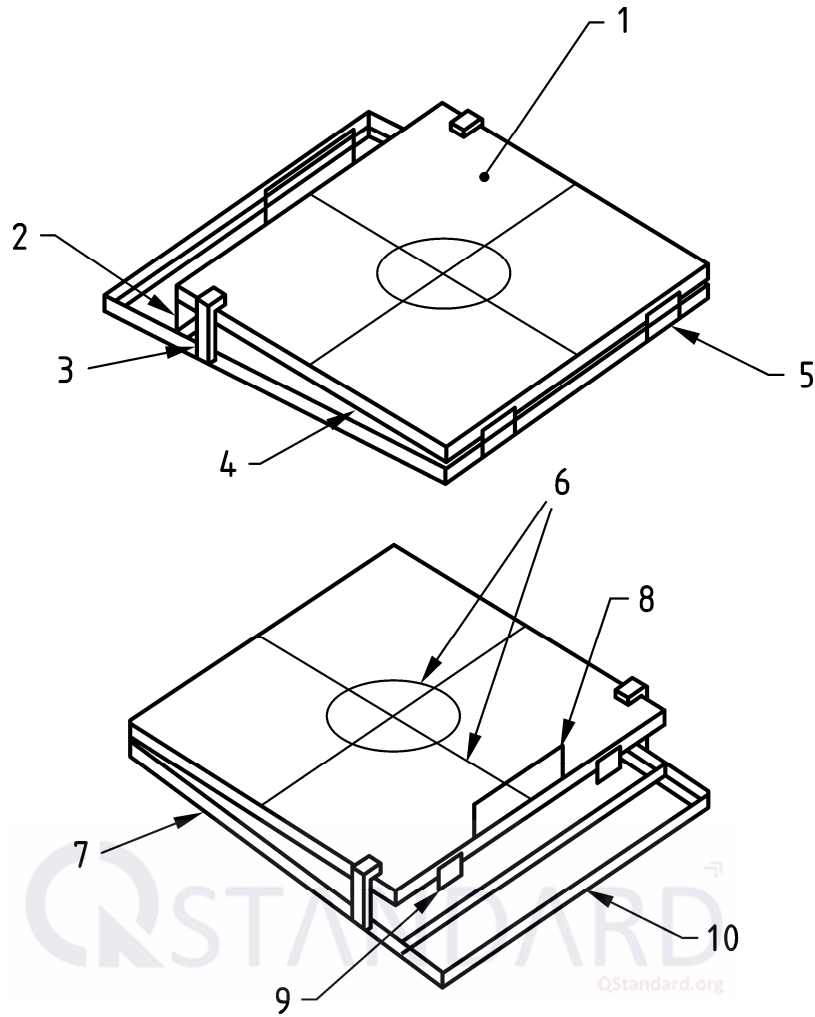

**Key**

- |                                  |                  |
|----------------------------------|------------------|
| 1 Metal plate                    | 6 Markings       |
| 2 Travel limited to $(40 \pm 1)$ | 7 Base frame     |
| 3 Upper stop                     | 8 Lifting handle |
| 4 Table top                      | 9 Lower stop     |
| 5 External hinges                | 10 Toe board     |

**Figure 1 — Typical flow table**

Dimensions in millimetres

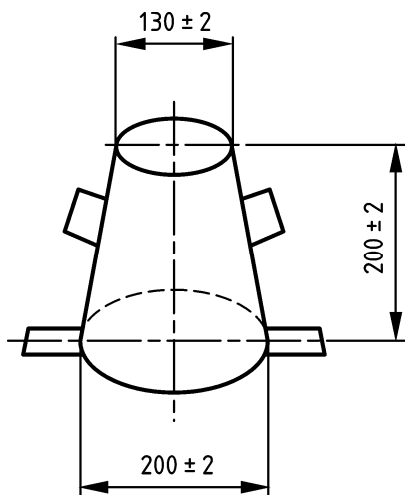

Figure 2 — Mould

Dimensions in millimetres

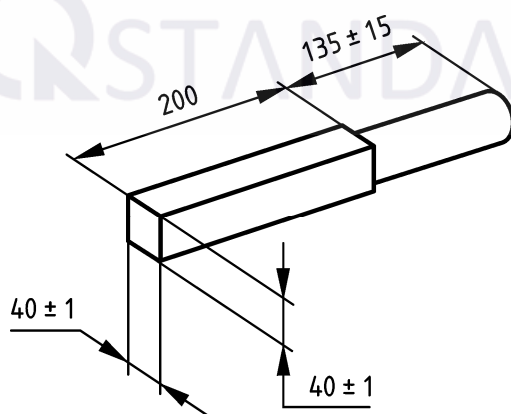

Figure 3 — Tamping bar

## 5 Sampling

The sample of the concrete shall be obtained in accordance with EN 12350-1.

The sample shall be re-mixed before carrying out the test using the remixing container and the square mouthed shovel.

NOTE Alternative sampling procedures may be given in national standards or provisions in the place of use of concrete.

## 6 Procedure

Place the flow table on a flat and horizontal surface free from external vibration or shock. Ensure that the hinged top of the table can be lifted to the correct limit of its travel and is then free to fall to the lower stop. Support the table in such a way that when the top of the table falls to the lower stop, there is minimal tendency for the top to bounce.

Clean the table and the mould and dampen immediately prior to testing, but keep free from superfluous moisture.

Keep the contact blocks clean. Place the mould centrally on the table top and hold in position by standing on the two foot pieces, or by using magnets.

Fill the mould with concrete in two equal layers using the scoop, levelling each layer by tamping lightly ten times with the compacting bar. If necessary add more concrete to the second layer to maintain an excess above the top of the mould. Using the compacting bar, strike off the concrete level with the upper edge of the mould and clean the area of the table top of any excess concrete.

After waiting 30 s from striking off the concrete, raise the mould vertically by the handles, over a period of 1 s to 3 s. Stabilize the flow table by standing on the toe board at the front of the table and slowly raise the table top till it reaches the upper stop in such a manner that the table top does not impact hard against the upper stop. Allow the table top to fall freely to the lower stop. Repeat this cycle to give a total of 15 drops, each cycle taking between 1 s and 3 s. With the rule, measure the maximum dimension of the concrete spread in the two directions,  $d_1$  and  $d_2$ , (see Figure 4), parallel to the table edges and record the two measurements to the nearest 10 mm.

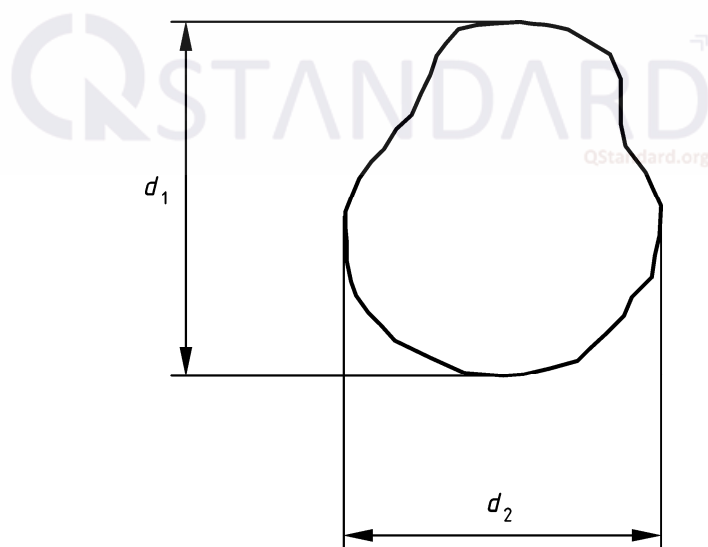

**Figure 4 — Measurement of spread**

Check the concrete spread for segregation. The cement paste may segregate from the coarse aggregate to give a ring of paste extending several millimetres beyond the coarse aggregate. Report whether segregation has occurred and if so that the test was therefore unsatisfactory.

After 15 cycles, if spread is not stabilized, wait until stabilization before measuring and record time between the end of the cycles and measurement. This time shall be mentioned in report.

**NOTE** The consistence of a concrete mix changes with time, due to hydration of the cement and, possibly, loss of moisture. Tests on different samples should be carried out at a constant time interval after mixing, if strictly comparable results are to be obtained.

## 7 Test results

The flow value  $f$ , is given by the formula:

$$f = \frac{d_1 + d_2}{2}$$

where:

- $d_1$  is the maximum dimension of the concrete spread, parallel to one table edge
- $d_2$  is the maximum dimension of the concrete spread, parallel to the other table edge

The result shall be reported to the nearest 10 mm.

## 8 Test report

The report shall include:

- a) identification of the test sample;
- b) location of performance of test;
- c) date of test;
- d) any indication of segregation of the concrete;
- e) for viscous concrete as defined above, time between the end of the cycles and measurement (in seconds);
- f) the flow value,  $f$ , to nearest 10 mm;
- g) any deviation from standard test method;
- h) declaration by the person technically responsible for the test that it was carried out in accordance with this document, except as noted in item f).

The report may include:

- i) temperature of the concrete specimen at time of test;
- j) time of performance of the test.

## 9 Precision

Precision data are given in Table 1. These apply to flow measurements made on concrete taken from the same sample and when each test result is obtained from a single flow determination.

**Table 1 — Precision data for flow measurement**

Level	Repeatability conditions		Reproducibility conditions	
	$S_r$ mm	$r$ mm	$S_R$ mm	$R$ mm
555	24,6	69	32,5	91

NOTE 1 The precision data were determined as part of an experiment carried out in the UK, in 1987 in which precision data were obtained for several tests then described in series BS 1881. The experiment involved 16 operators. The concretes were made using an ordinary Portland cement, Thames Valley sand, and Thames Valley 10 mm and 20 mm coarse aggregates.

NOTE 2 The difference between two test results from the same sample by one operator using the same apparatus within the shortest feasible time interval will exceed the repeatability value  $r$  on average not more than once in 20 cases in the normal and correct operation of the method.

NOTE 3 Test results on the same ample obtained within the shortest feasible time interval by two operators each using their own apparatus will differ by the reproducibility value  $R$  on average not more than once in 20 cases in the normal and correct operation of the method.

NOTE 4 For further information on precision, and for definitions of the statistical terms used in connection with precision, see series ISO 5725.

---

## BSI - British Standards Institution

BSI is the independent national body responsible for preparing British Standards. It presents the UK view on standards in Europe and at the international level. It is incorporated by Royal Charter.

### Revisions

British Standards are updated by amendment or revision. Users of British Standards should make sure that they possess the latest amendments or editions.

It is the constant aim of BSI to improve the quality of our products and services. We would be grateful if anyone finding an inaccuracy or ambiguity while using this British Standard would inform the Secretary of the technical committee responsible, the identity of which can be found on the inside front cover. Tel: +44 (0)20 8996 9000. Fax: +44 (0)20 8996 7400.

BSI offers members an individual updating service called PLUS which ensures that subscribers automatically receive the latest editions of standards.

### Buying standards

Orders for all BSI, international and foreign standards publications should be addressed to Customer Services. Tel: +44 (0)20 8996 9001. Fax: +44 (0)20 8996 7001 Email: [orders@bsigroup.com](mailto:orders@bsigroup.com) You may also buy directly using a debit/credit card from the BSI Shop on the Website <http://www.bsigroup.com/shop>

In response to orders for international standards, it is BSI policy to supply the BSI implementation of those that have been published as British Standards, unless otherwise requested.

### Information on standards

BSI provides a wide range of information on national, European and international standards through its Library and its Technical Help to Exporters Service. Various BSI electronic information services are also available which give details on all its products and services. Contact Information Centre. Tel: +44 (0)20 8996 7111 Fax: +44 (0)20 8996 7048 Email: [info@bsigroup.com](mailto:info@bsigroup.com)

Subscribing members of BSI are kept up to date with standards developments and receive substantial discounts on the purchase price of standards. For details of these and other benefits contact Membership Administration. Tel: +44 (0)20 8996 7002 Fax: +44 (0)20 8996 7001 Email: [membership@bsigroup.com](mailto:membership@bsigroup.com)

Information regarding online access to British Standards via British Standards Online can be found at <http://www.bsigroup.com/BSOL>

Further information about BSI is available on the BSI website at <http://www.bsigroup.com>.

### Copyright

Copyright subsists in all BSI publications. BSI also holds the copyright, in the UK, of the publications of the international standardization bodies. Except as permitted under the Copyright, Designs and Patents Act 1988 no extract may be reproduced, stored in a retrieval system or transmitted in any form or by any means – electronic, photocopying, recording or otherwise – without prior written permission from BSI.

This does not preclude the free use, in the course of implementing the standard, of necessary details such as symbols, and size, type or grade designations. If these details are to be used for any other purpose than implementation then the prior written permission of BSI must be obtained.

Details and advice can be obtained from the Copyright and Licensing Manager. Tel: +44 (0)20 8996 7070 Email: [copyright@bsigroup.com](mailto:copyright@bsigroup.com)